

External Door Selector

Feature Doors



Suffolk Oak
Page number 65



Croft Glazed Oak
Page number 66



Chancery Oak
Stable Glazed
Page number 67



Malton Glazed Oak
Page number 68



London Oak
Page number 69



Georgia Glazed Oak
Page number 70



Avon Glazed Oak
Page number 71



Newton Glazed Oak
Page number 72



Oxford Glazed Oak
Page number 73



York Glazed Oak
Page number 74



Colonial Hardwood
Page number 75



Carolina Hardwood
Page number 76



Malton Hardwood
Page number 77



Stable 1 Light
Hardwood
Page number 78



London Hardwood
Page number 79



2XG Hardwood
Page number 80

Cut out shows unfinished door.

Softwood Doors



2XG Double Glazed
Page number 81



Framed Ledged
and Braced
Page number 82



Ledged and Braced
Page number 83



Garage Double Door
Page number 84

Flush Doors



Ply Flush
Page number 85



Door Blank
Page number 86

Cut out shows unfinished door.

Folding Doors



Solid Oak 54mm Pattern 10
Page number 88



Oak Veneer 54mm Pattern 10
Page number 89



Softwood 44mm Pattern 10
Page number 90

French Doors



Solid Oak 54mm Pattern 10
Page number 91



Oak Veneer 46mm Pattern 10
Page number 92



Softwood 44mm Pattern 10
Page number 93



Softwood 44mm Georgian
Page number 94

External Doors

External doors are available in a wide range of sizes and finishes – ask for further details at your local Benchmarx branch, our joinery specialists can offer all the advice you'll need to help you complete your project.

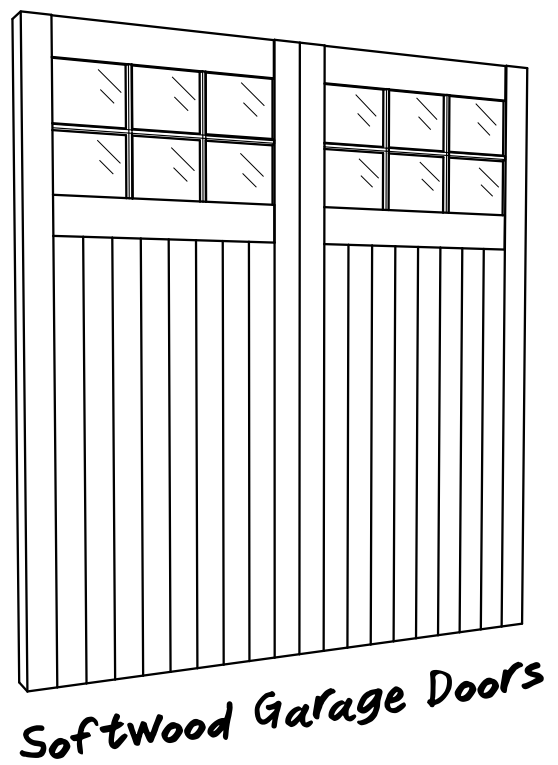
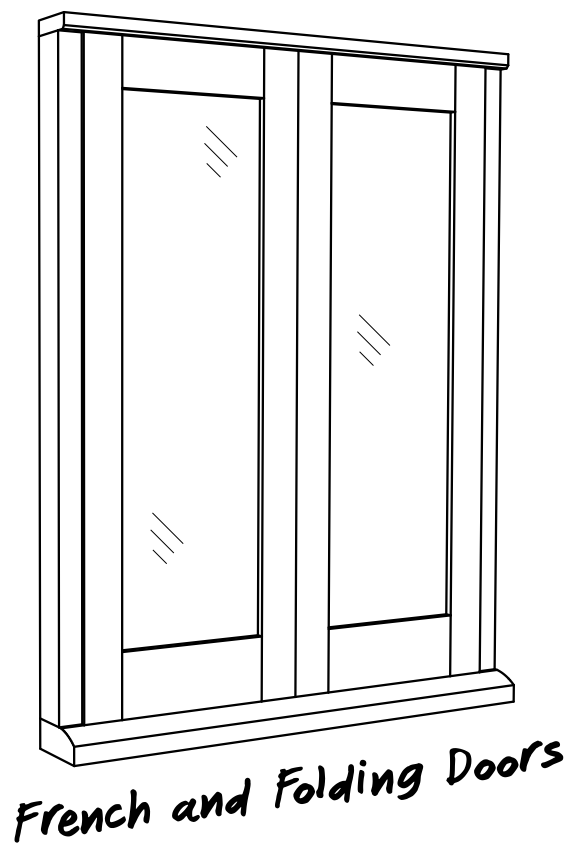
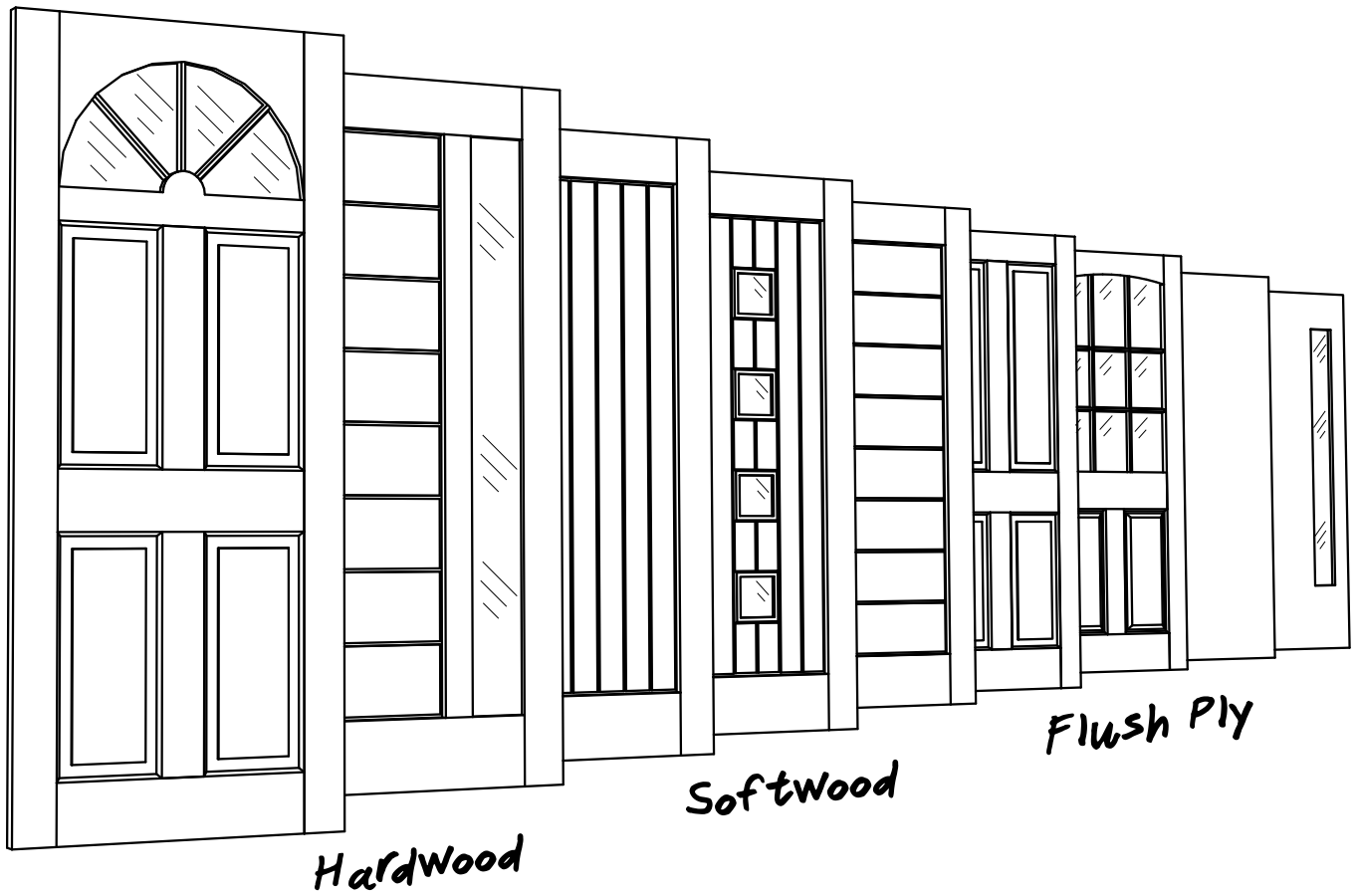

External Doors

Typical External Door

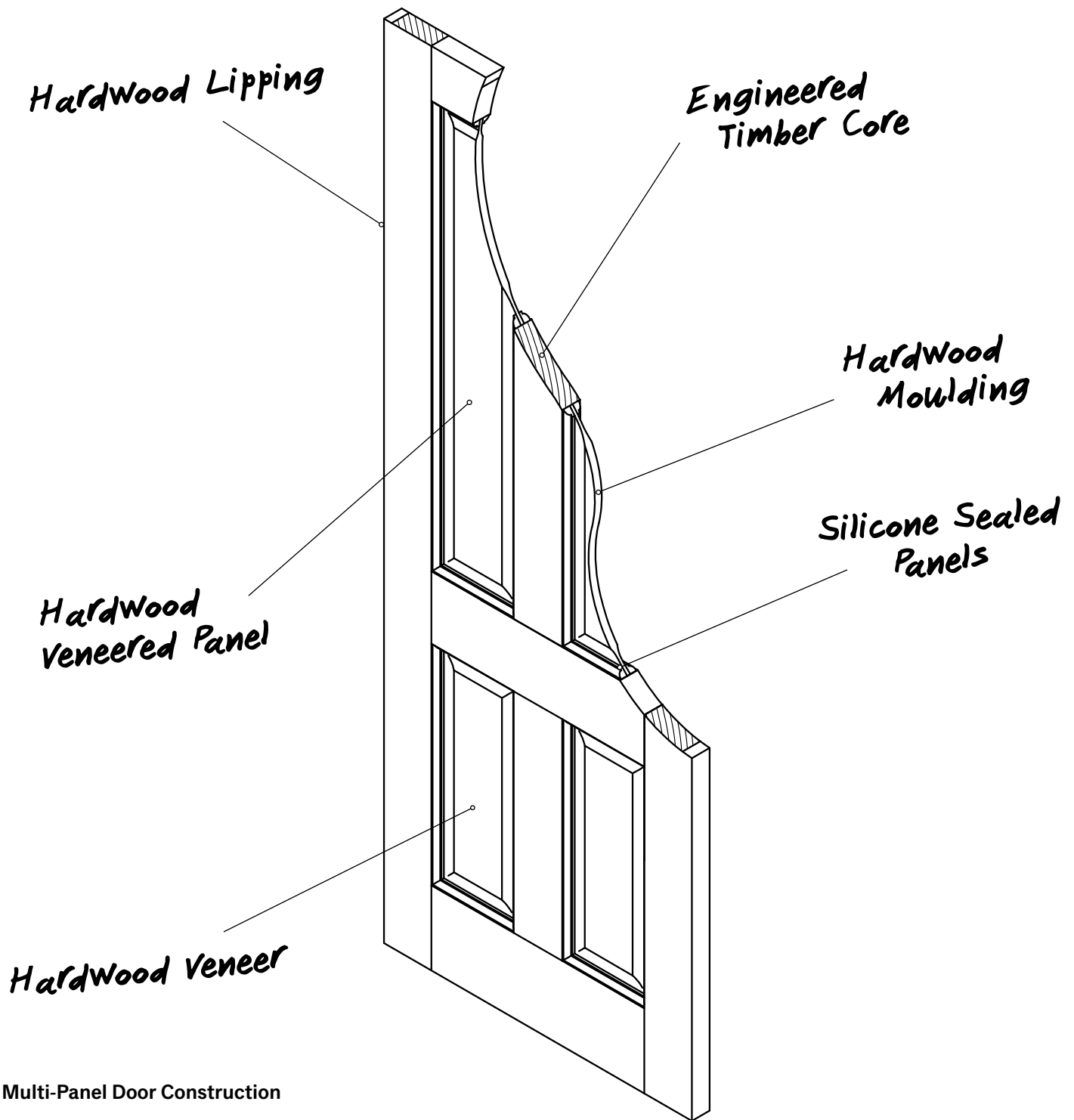

Multi-Panel Door Construction

Our hardwood external doors are built to last – we use a variety of assembly techniques, ranging from traditional mortice and tenon joints, to glue and dowel construction.

External Doors

Traditional Assembly Methods

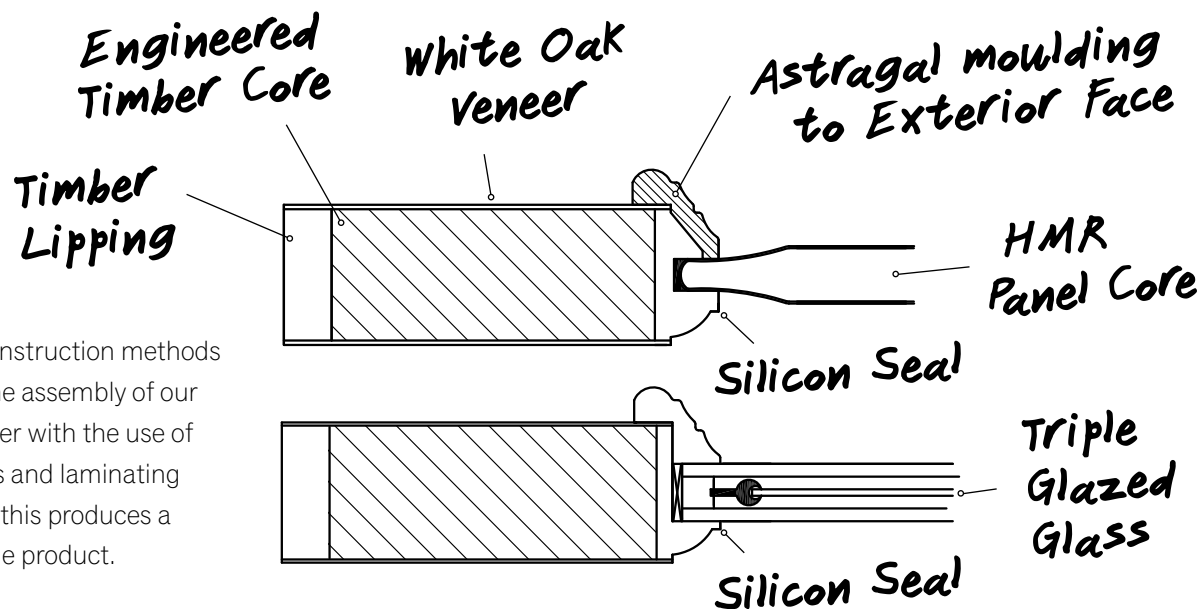

Traditional construction methods are used in the assembly of our doors, together with the use of modern glues and laminating techniques – this produces a durable, stable product.

Commercial Applications

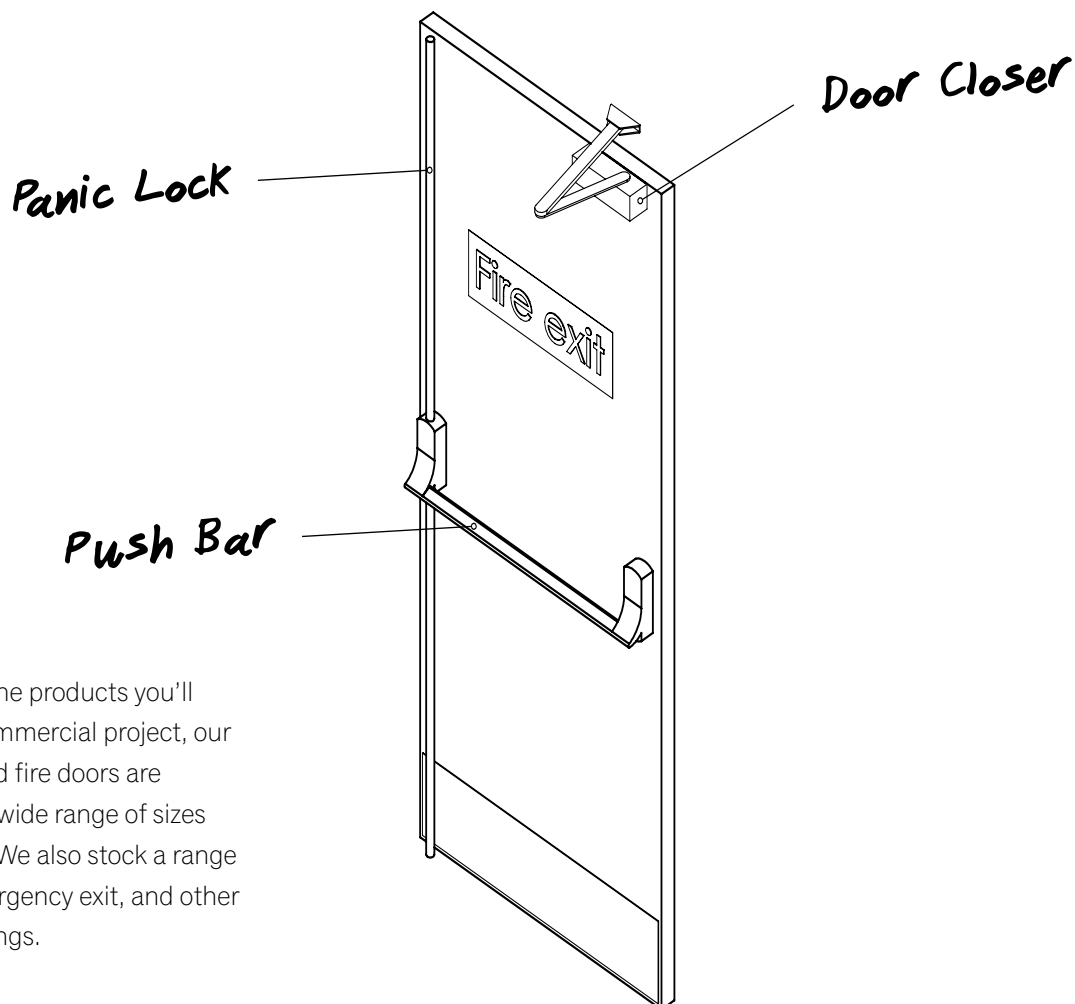

We stock all the products you'll need for a commercial project, our plywood-faced fire doors are available in a wide range of sizes and finishes. We also stock a range of panic, emergency exit, and other specialist fittings.

External Doors – French, Sliding and Folding Doors

Our range of sliding and bi-fold doors give the opportunity to create your own grand design. Open up the home interior to fresh air and outdoor lifestyle – perfect for a summer barbeque and friends!

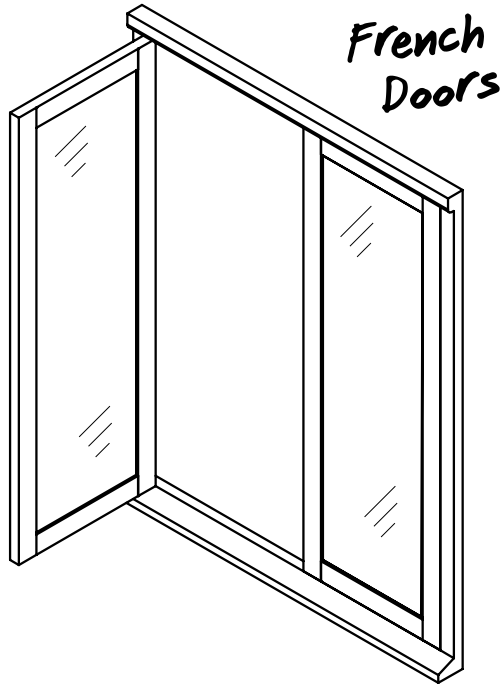

The traditional solution for patio living

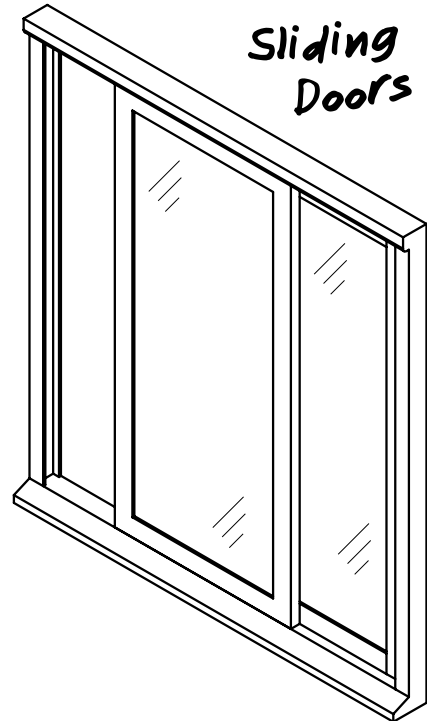

Modern convenience and versatility

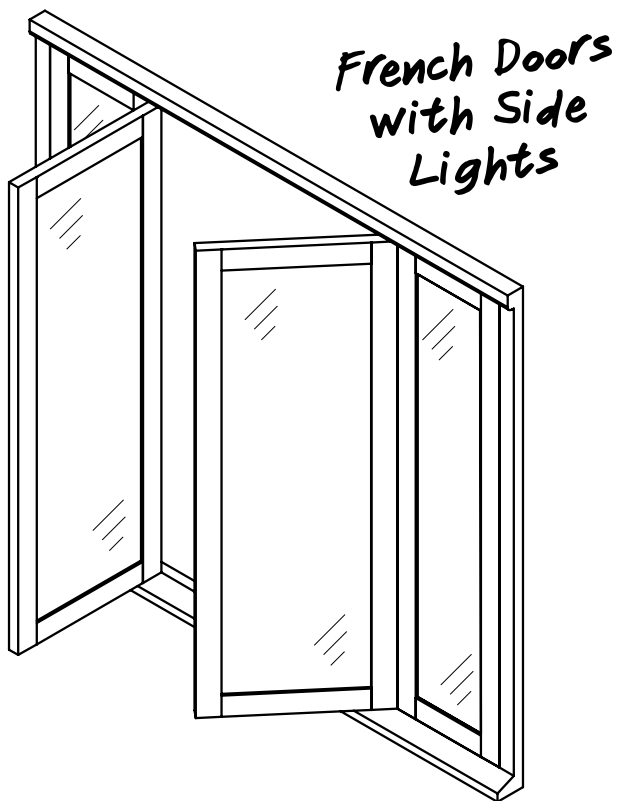

If you have more space, why not bring more light into your home?

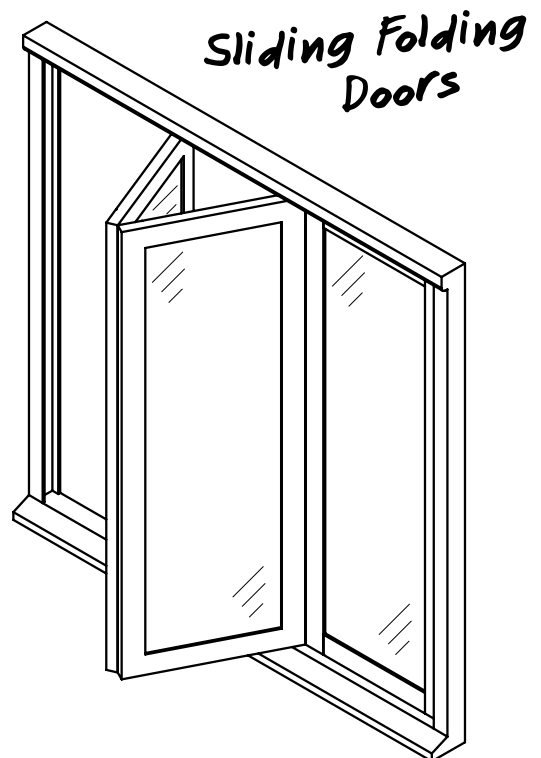

Let the outside in!!